



Hygienic Flow Equipment

3A PVE Single Seat Valves



Originally installed in 2005, these high quality EGMO single seat valves, still provide excellent service to this dairy manufacturing plant.



3A PVE Single Seat Valves

MaxClean single seat valve for sanitary applications (pneumatic / manually operated)

PVE Valves are available in three operating modules: Air Actuated; Air Actuated with an electronic control head; and manually operated. PVE valves popular applications are the following: Shut-off Valve, Divert Valve, Tank Outlet and Pressure Relief Valve. Connections consist of Clamp, Weld, Bevel Seat, and E-Line. EGMO's PVE Valves are made of AISI 316L Stainless steel which meet all 3A requirements and are offered in 1" through 4" sizes. Unique patent pending sealing system.

Valve Series



**Shut-Off
Valve**



**Divert
Valve**



**Pressure
Relief Valve**



**Tank bottom
Valve**

Content

Shut-Off Valve.....	page 6
Divert Valve.....	page 12
Pressure Relief Valve.....	page 20
Tank bottom valve.....	page 21
Control head.....	page 26
Maximum Working Pressure Data.....	page 30

3A PVE Features and Benefits

Standards



Robust and Durable

- ✓ Due to the valve's unique structure, the O-ring remains protected from wear and exposure to abrasive media
- ✓ AISI 316L stainless-steel body and parts, made from bar for maximum durability and cleanability
- ✓ Designed to withstand up to 1M operations



Smart Installation and Operation

- ✓ 360° adjustable
- ✓ Simple adjustment between Normally open / Normally closed with no need for actuator change
- ✓ Suitable for Shut off, Divert and Vessel outlet configurations

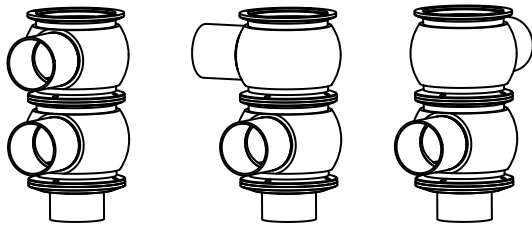

Sterility

- ✓ One-part stem for optimal sterility and aseptic applications
- ✓ Process contact components are electro-polished for corrosion resistance & reduced risk of bacterial growth
- ✓ Inside surface finish $\leq 32 \mu\text{m Ra}$
- ✓ Full drainage without dead leg



Optimal CIP Cleaning

- ✓ Ball shape and surfaces - no dead spaces
- ✓ O-ring seat in the valve ensures minimal exposure to the flow

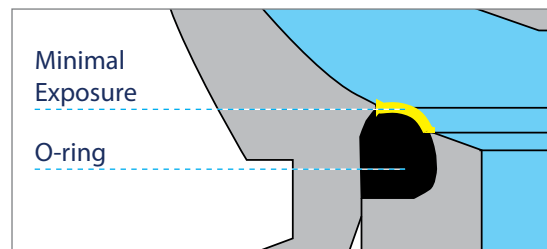

Cost Effective Maintenance

- ✓ Both top and bottom parts of the valve are identical
- ✓ Unique Patent Pending sealing system utilizing standard O-ring sealing



3A PVE - Shut-off Valve

Used for opening and closing the fluids path

- ✓ Spherical shape with zero dead leg
- ✓ Easy to maintain with standard O-Ring
- ✓ Fast changeover from N/C to N/O fail position
- ✓ Clamp connection between the valve parts
- ✓ Butt weld or clamp ends
- ✓ Minimum gasket exposure
- ✓ Visual bleeding hole to inspect leaks
- ✓ Hygienic modules
- ✓ Process contact components are electric-polished
- ✓ Inside surface finish $\leq 32 \mu\text{m Ra}$

N/C and N/O operations in one actuator

Robust, ball-shaped body made of AISI 316L stainless-steel (made from full bar)

Static O-ring to minimize wear and erosion
Minimal exposure of the O-ring to the flow

Optimum CIP cleaning due to ball shape and surfaces -
no dead spaces



Configuration and Flow direction options

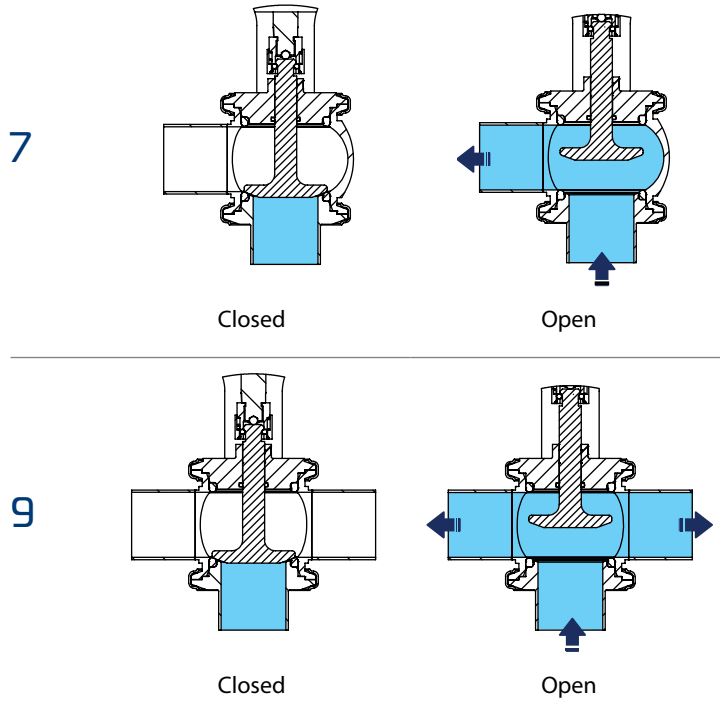

How To Order

E **G** **P** **V** **E** - **7** - **N** **C** - **1** . **0** - **V** - **A** **S** **I**

Valve Type Valve Configuration Actuation Type Size Seals Control Head

Type Connection	Valve Configuration	Actuation Type	Size	Seals	Control Head
EGPVE - CLAMP	7 - Shut Off	NC	1.0	DEFAULT - EPDM	ASI
EPVE - WELD	9 - Cross Shut Off	NO	1.5	V - Viton	24V
		MAN	2.0	S - Silicone	110V
			2.5		1IPS - One Inductive Proximity Switch
			3.0		2IPS - Two Inductive Proximity Switch
			4.0		(Proximity Switch Diameter 12mm)

* See page 26 for Control head details



3A PVE Shut-Off Valve Dimensions

Weld Ends (7)

Size/OD		Name	Item	A	B	C	E	G	F
1" (25.4)	Epdm	EPVE-7-NC-1.0	611-00684	11.00 (279.5)	2.00 (50.8)	2.00 (50.8)	2.76 (70)	1.18 (30)	0.43 (11)
	Viton	EPVE-7-NC-1.0-V	611-00829						
	Silicone	EPVE-7-NC-1.0-S	611-00936						
1½" (38.1)	Epdm	EPVE-7-NC-1.5	611-00438	13.66 (347)	2.24 (57)	2.76 (70)	4.00 (101.6)	1.46 (37)	1.00 (25.4)
	Viton	EPVE-7-NC-1.5-V	611-00025						
	Silicone	EPVE-7-NC-1.5-S	611-00937						
2" (50.8)	Epdm	EPVE-7-NC-2.0	611-00037	14.57 (370)	3.00 (76.2)	3.50 (89)	4.00 (101.6)	1.42 (36)	1.06 (26.8)
	Viton	EPVE-7-NC-2.0-V	611-00030						
	Silicone	EPVE-7-NC-2.0-S	611-00938						
2½" (63.5)	Epdm	EPVE-7-NC-2.5	611-00496	16.38 (416)	3.00 (76.2)	3.50 (89)	5.08 (129)	1.69 (43)	1.46 (37.1)
	Viton	EPVE-7-NC-2.5-V	611-00052						
	Silicone	EPVE-7-NC-2.5-S	611-00939						
3" (76.2)	Epdm	EPVE-7-NC-3.0	611-00441	17.05 (433)	3.27 (83)	3.74 (95)	5.08 (129)	1.69 (43)	1.53 (38.9)
	Viton	EPVE-7-NC-3.0-V	611-00830						
	Silicone	EPVE-7-NC-3.0-S	611-00940						
4" (101.6)	Epdm	EPVE-7-NC-4.0	611-00499	21.42 (544)	5.00 (127)	4.92 (125)	6.61 (168)	1.65 (42)	1.26 (32)
	Viton	EPVE-7-NC-4.0-V	611-00887						
	Silicone	EPVE-7-NC-4.0-S	611-00941						

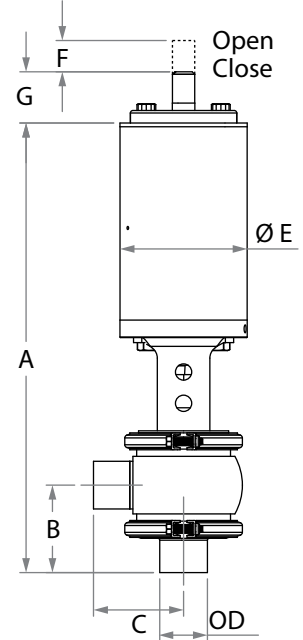

Clamp Ends (7)

Size/OD		Name	Item	A	B	C	E	G	F
1" (25.4)	Epdm	EGPVE-7-NC-1.0	611-00739	11.00 (279.5)	2.00 (50.8)	2.00 (50.8)	2.76 (70)	1.18 (30)	0.43 (11)
	Viton	EGPVE-7-NC-1.0-V	611-00803						
	Silicone	EGPVE-7-NC-1.0-S	611-00897						
1½" (38.1)	Epdm	EGPVE-7-NC-1.5	611-00016	14.13 (359)	2.76 (70)	2.76 (70)	4.00 (101.6)	1.46 (37)	1.00 (25.4)
	Viton	EGPVE-7-NC-1.5-V	611-00767						
	Silicone	EGPVE-7-NC-1.5-S	611-00544						
2" (50.8)	Epdm	EGPVE-7-NC-2.0	611-00035	15.08 (383)	3.50 (89)	3.50 (89)	4.00 (101.6)	1.42 (36)	1.06 (26.8)
	Viton	EGPVE-7-NC-2.0-V	611-00766						
	Silicone	EGPVE-7-NC-2.0-S	611-00898						
2½" (63.5)	Epdm	EGPVE-7-NC-2.5	611-00419	16.89 (429)	3.50 (89)	3.50 (89)	5.08 (129)	1.69 (43)	1.46 (37.1)
	Viton	EGPVE-7-NC-2.5-V	611-00804						
	Silicone	EGPVE-7-NC-2.5-S	611-00899						
3" (76.2)	Epdm	EGPVE-7-NC-3.0	611-00418	17.56 (446)	3.74 (95)	3.74 (95)	5.08 (129)	1.69 (43)	1.53 (38.9)
	Viton	EGPVE-7-NC-3.0-V	611-00590						
	Silicone	EGPVE-7-NC-3.0-S	611-00900						
4" (101.6)	Epdm	EGPVE-7-NC-4.0	611-00872	21.42 (544)	5.00 (127)	4.92 (125)	6.61 (168)	1.65 (42)	1.26 (32)
	Viton	EGPVE-7-NC-4.0-V	611-00884						
	Silicone	EGPVE-7-NC-4.0-S	611-00901						

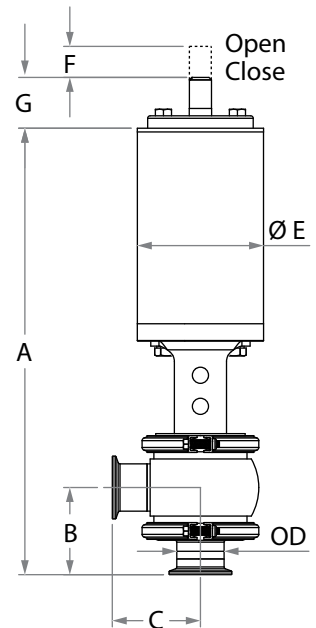

Weld Ends (9)

Size/OD		Name	Item	A	B	C	E	G	F
1" (25.4)	Epdm	EPVE-9-NC-1.0	611-00686	11.00 (279.5)	2.00 (50.8)	2.00 (50.8)	2.76 (70)	1.18 (30)	0.43 (11)
	Viton	EPVE-9-NC-1.0-V	611-00849						
	Silicone	EPVE-9-NC-1.0-S	611-00954						
1½" (38.1)	Epdm	EPVE-9-NC-1.5	611-00473	13.66 (347)	2.24 (57)	2.76 (70)	4.00 (101.6)	1.46 (37)	1.00 (25.4)
	Viton	EPVE-9-NC-1.5-V	611-00517						
	Silicone	EPVE-9-NC-1.5-S	611-00955						
2" (50.8)	Epdm	EPVE-9-NC-2.0	611-00047	14.57 (370)	3.00 (76.2)	3.50 (89)	4.00 (101.6)	1.42 (36)	1.06 (26.8)
	Viton	EPVE-9-NC-2.0-V	611-00048						
	Silicone	EPVE-9-NC-2.0-S	611-00956						
2½" (63.5)	Epdm	EPVE-9-NC-2.5	611-00506	16.38 (416)	3.00 (76.2)	3.50 (89)	5.08 (129)	1.69 (43)	1.46 (37.1)
	Viton	EPVE-9-NC-2.5-V	611-00050						
	Silicone	EPVE-9-NC-2.5-S	611-00957						
3" (76.2)	Epdm	EPVE-9-NC-3.0	611-00508	17.05 (433)	3.27 (83)	3.74 (95)	5.08 (129)	1.69 (43)	1.53 (38.9)
	Viton	EPVE-9-NC-3.0-V	611-00851						
	Silicone	EPVE-9-NC-3.0-S	611-00958						
4" (101.6)	Epdm	EPVE-9-NC-4.0	611-00879	21.42 (544)	5.00 (127)	4.92 (125)	6.61 (168)	1.65 (42)	1.26 (32)
	Viton	EPVE-9-NC-4.0-V	611-00895						
	Silicone	EPVE-9-NC-4.0-S	611-00959						

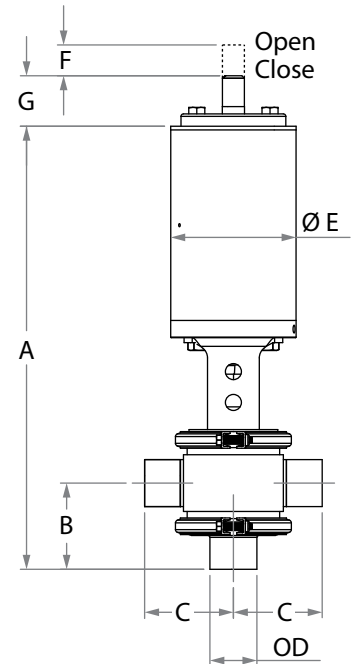

Clamp Ends (9)

Size/OD		Name	Item	A	B	C	E	G	F
1" (25.4)	Epdm	EGPVE-9-NC-1.0	611-00469	11.00 (279.5)	2.00 (50.8)	2.00 (50.8)	2.76 (70)	1.18 (30)	0.43 (11)
	Viton	EGPVE-9-NC-1.0-V	611-00757						
	Silicone	EGPVE-9-NC-1.0-S	611-00914						
1½" (38.1)	Epdm	EGPVE-9-NC-1.5	611-00432	14.13 (359)	2.76 (70)	2.76 (70)	4.00 (101.6)	1.46 (37)	1.00 (25.4)
	Viton	EGPVE-9-NC-1.5-V	611-00733						
	Silicone	EGPVE-9-NC-1.5-S	611-00915						
2" (50.8)	Epdm	EGPVE-9-NC-2.0	611-00068	15.08 (383)	3.50 (89)	3.50 (89)	4.00 (101.6)	1.42 (36)	1.06 (26.8)
	Viton	EGPVE-9-NC-2.0-V	611-00727						
	Silicone	EGPVE-9-NC-2.0-S	611-00916						
2½" (63.5)	Epdm	EGPVE-9-NC-2.5	611-00417	16.89 (429)	3.50 (89)	3.50 (89)	5.08 (129)	1.69 (43)	1.46 (37.1)
	Viton	EGPVE-9-NC-2.5-V	611-00538						
	Silicone	EGPVE-9-NC-2.5-S	611-00917						
3" (76.2)	Epdm	EGPVE-9-NC-3.0	611-00489	17.56 (446)	3.74 (95)	3.74 (95)	5.08 (129)	1.69 (43)	1.53 (38.9)
	Viton	EGPVE-9-NC-3.0-V	611-00734						
	Silicone	EGPVE-9-NC-3.0-S	611-00918						
4" (101.6)	Epdm	EGPVE-9-NC-4.0	611-00877	21.42 (544)	5.00 (127)	4.92 (125)	6.61 (168)	1.65 (42)	1.26 (32)
	Viton	EGPVE-9-NC-4.0-V	611-00894						
	Silicone	EGPVE-9-NC-4.0-S	611-00919						

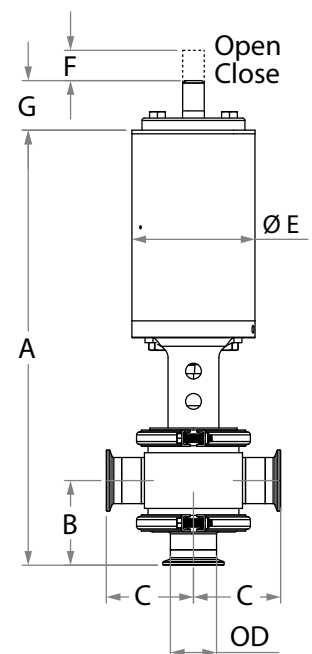

3A PVE Shut-Off Valve Components & Materials

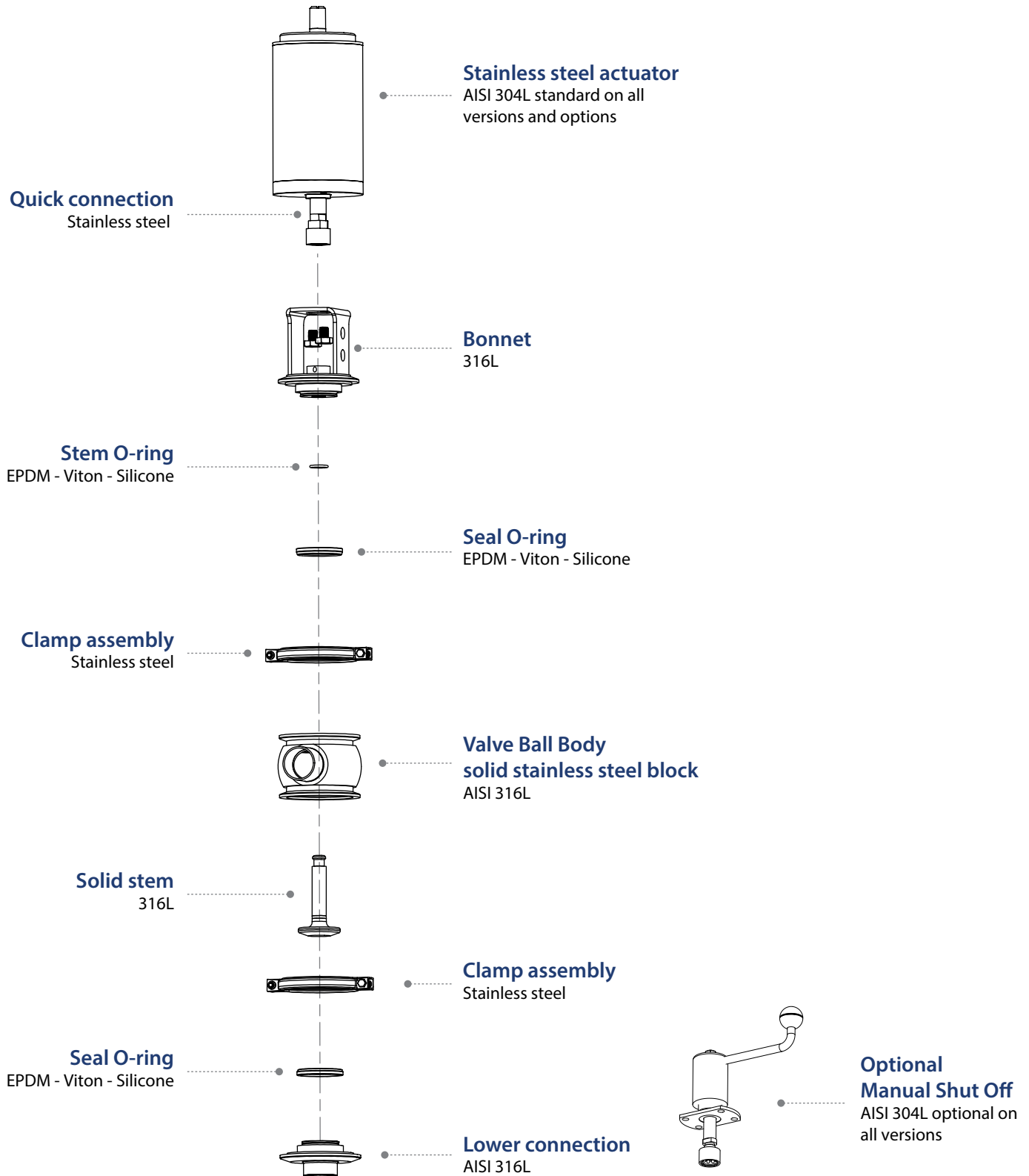

3A PVE - Shut-Off Valve Pressure Drop Vs Flow Rate Capacity Diagram

$$HI = \frac{K \cdot F^2}{2g \cdot D^4}$$

HI - Head Loss [ft]
 K - Loss coefficient []
 F - Flow Rate capacity [ft³/h]
 g - Gravitational acceleration [ft/s²]
 D - Valve diameter [inch]

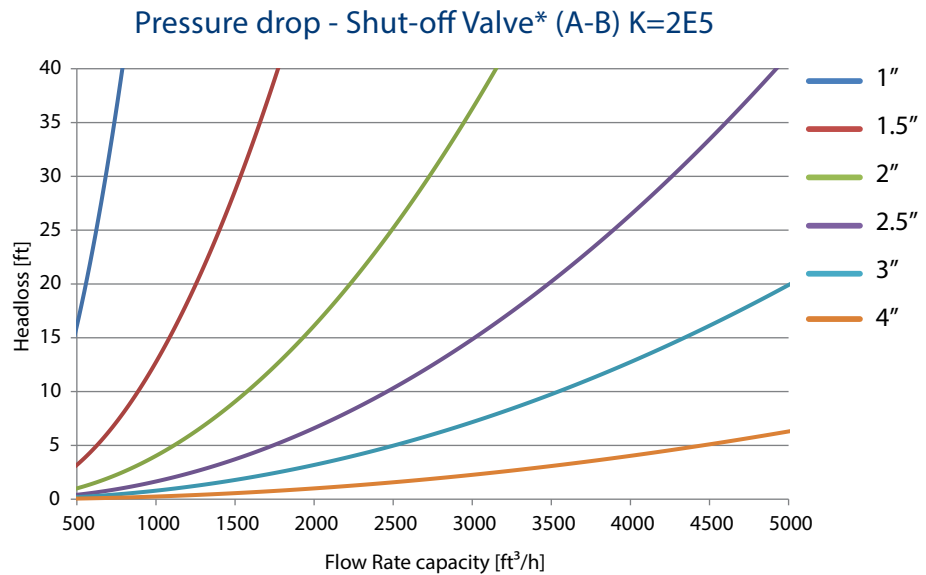
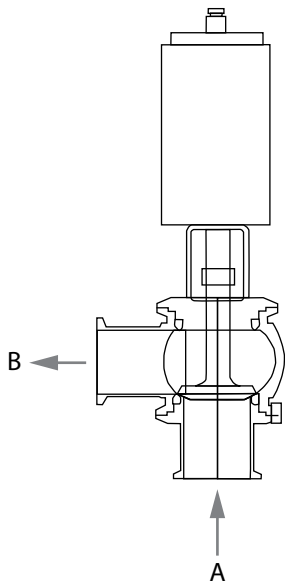

* For additional valve configuration (9) please refer to EGMO website



3A PVE - Divert Valve

Used for opening / closing or changing the fluids path

- ✓ Spherical shape with zero dead leg
- ✓ Easy to maintain with standard O-Ring
- ✓ Fast changeover from N/C to N/O fail position
- ✓ Clamp connection between the valve parts
- ✓ Butt weld or clamp ends
- ✓ Minimum gasket exposure
- ✓ Visual bleeding hole to inspect leaks
- ✓ Hygienic modules
- ✓ Process contact components are electric-polished
- ✓ Inside surface finish $\leq 32 \mu\text{m Ra}$

N/C and N/O operations in one actuator

Minimal exposure of the O-ring to the flow

Robust, ball-shaped body made of AISI 316L stainless-steel (made from full bar)

Static O-ring to minimize wear and erosion

Optimum CIP cleaning due to ball shape and surfaces - no dead spaces



Configuration and Flow direction options

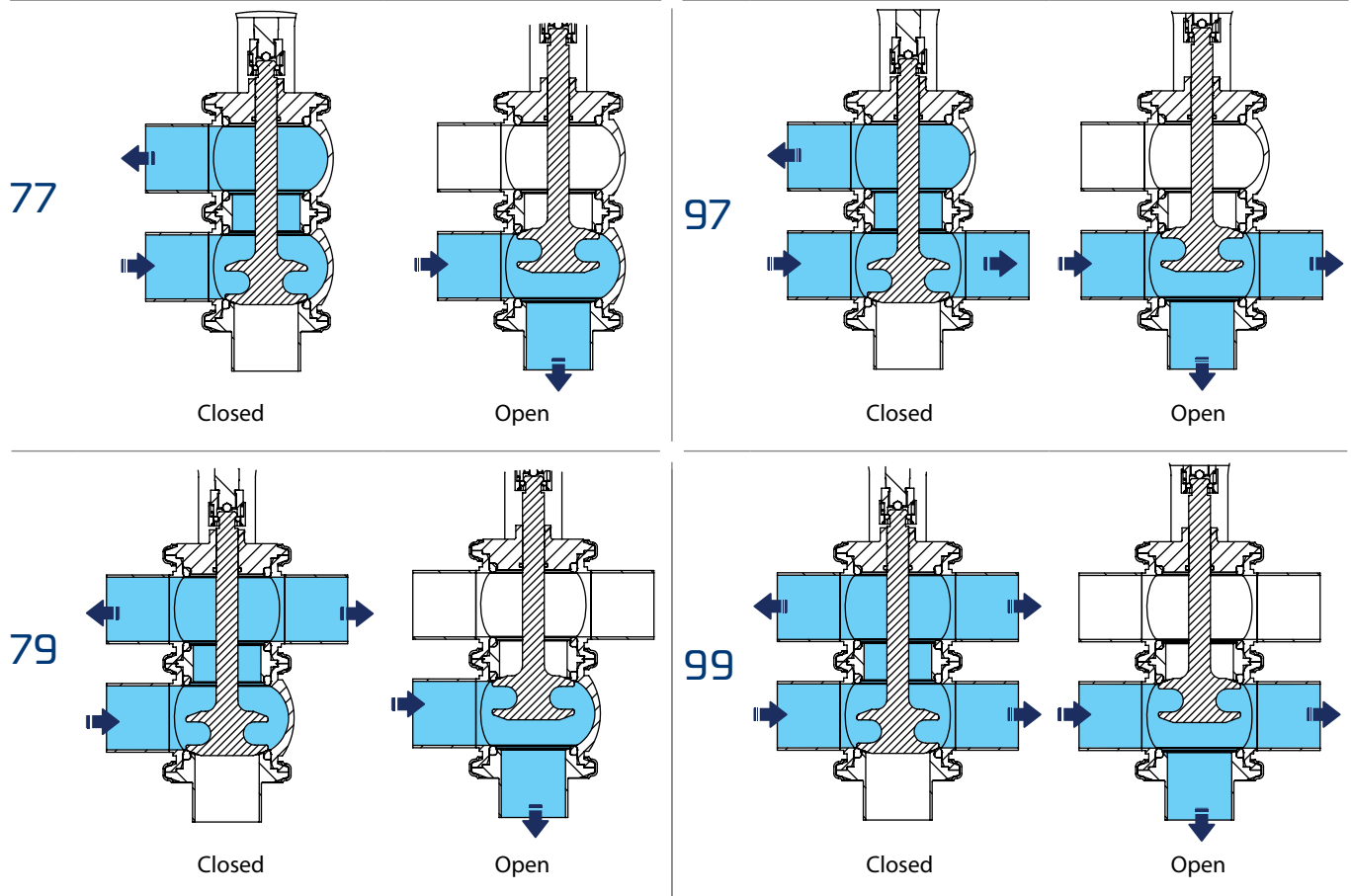

How To Order

E G P V E - 7 7 - N C - 1 . 0 - V - A S I

Valve Type

Valve Configuration

Actuation Type

Size

Seals

Control Head

Type Connection	Valve Configuration	Actuation Type	Size	Seals	Control Head
EGPVE - CLAMP	77 - Divert	NC	1.0	DEFAULT - EPDM	ASI
EPVE - WELD	79 - Divert	NO	1.5	V - Viton	24V
	97 - Divert	MAN	2.0	S - Silicone	110V
	99 - Divert		2.5		11PS - One Inductive Proximity Switch
			3.0		21PS - Two Inductive Proximity Switch
			4.0		(Proximity Switch Diameter 12mm)

* See page 26 for Control head details

3A PVE Divert Valve Dimensions

Weld Ends (77)

Size/OD		Name	Item	A	B	C	E	G	H	F
1" (25.4)	Epdm	EPVE-77-NC-1.0	611-00688	13.00 (330.2)	2.00 (50.8)	2.00 (50.8)	2.76 (70)	1.18 (30)	1.97 (50)	0.39 (10)
	Viton	EPVE-77-NC-1.0-V	611-00866							
	Silicone	EPVE-77-NC-1.0-S	611-00942							
1½" (38.1)	Epdm	EPVE-77-NC-1.5	611-00020	16.38 (416)	2.24 (57)	2.76 (70)	4.00 (101.6)	1.38 (35)	2.76 (70)	0.96 (24.5)
	Viton	EPVE-77-NC-1.5-V	611-00863							
	Silicone	EPVE-77-NC-1.5-S	611-00943							
2" (50.8)	Epdm	EPVE-77-NC-2.0	611-00041	17.76 (451)	3.00 (76.2)	3.50 (89)	4.00 (101.6)	1.38 (35)	3.11 (79)	0.96 (24.4)
	Viton	EPVE-77-NC-2.0-V	611-00475							
	Silicone	EPVE-77-NC-2.0-S	611-00944							
2½" (63.5)	Epdm	EPVE-77-NC-2.5	611-00494	20.28 (515)	3.00 (76.2)	3.50 (89)	5.08 (129)	1.69 (43)	3.94 (100)	1.33 (33.9)
	Viton	EPVE-77-NC-2.5-V	611-00055							
	Silicone	EPVE-77-NC-2.5-S	611-00945							
3" (76.2)	Epdm	EPVE-77-NC-3.0	611-00442	21.85 (555)	3.27 (83)	3.74 (95)	5.08 (129)	1.54 (39)	4.76 (121)	1.36 (34.5)
	Viton	EPVE-77-NC-3.0-V	611-00065							
	Silicone	EPVE-77-NC-3.0-S	611-00946							
4" (101.6)	Epdm	EPVE-77-NC-4.0	611-00875	27.32 (694)	5.00 (127)	4.92 (125)	6.61 (168)	1.65 (42)	5.91 (150)	1.18 (30)
	Viton	EPVE-77-NC-4.0-V	611-00888							
	Silicone	EPVE-77-NC-4.0-S	611-00947							

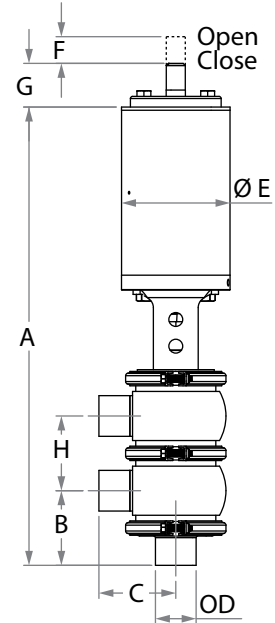

Clamp Ends (77)

Size/OD		Name	Item	A	B	C	E	G	H	F
1"* (25.4)	Epdm	EGPVE-77-NC-1.0	611-00749	12.91 (328)	2.00 (50.8)	2.00 (50.8)	2.76 (70)	1.26 (32)	1.89 (48)	0.39 (10)
	Viton	EGPVE-77-NC-1.0-V	611-00861							
	Silicone	EGPVE-77-NC-1.0-S	611-00902							
1½" (38.1)	Epdm	EGPVE-77-NC-1.5	611-00018	16.89 (429)	2.76 (70)	2.76 (70)	4.00 (101.6)	1.38 (35)	2.76 (70)	0.96 (24.5)
	Viton	EGPVE-77-NC-1.5-V	611-00768							
	Silicone	EGPVE-77-NC-1.5-S	611-00903							
2" (50.8)	Epdm	EGPVE-77-NC-2.0	611-00039	18.27 (464)	3.50 (89)	3.50 (89)	4.00 (101.6)	1.38 (35)	3.11 (79)	0.96 (24.4)
	Viton	EGPVE-77-NC-2.0-V	611-00769							
	Silicone	EGPVE-77-NC-2.0-S	611-00904							
2½" (63.5)	Epdm	EGPVE-77-NC-2.5	611-00053	20.75 (527)	3.50 (89)	3.50 (89)	5.08 (129)	1.69 (43)	3.94 (100)	1.33 (33.9)
	Viton	EGPVE-77-NC-2.5-V	611-00862							
	Silicone	EGPVE-77-NC-2.5-S	611-00905							
3" (76.2)	Epdm	EGPVE-77-NC-3.0	611-00063	22.36 (568)	3.74 (95)	3.74 (95)	5.08 (129)	1.54 (39)	4.76 (121)	1.36 (34.5)
	Viton	EGPVE-77-NC-3.0-V	611-00591							
	Silicone	EGPVE-77-NC-3.0-S	611-00906							
4" (101.6)	Epdm	EGPVE-77-NC-4.0	611-00874	27.32 (694)	5.00 (127)	4.88 (124)	6.61 (168)	1.65 (42)	5.91 (150)	1.18 (30)
	Viton	EGPVE-77-NC-4.0-V	611-00885							
	Silicone	EGPVE-77-NC-4.0-S	611-00907							

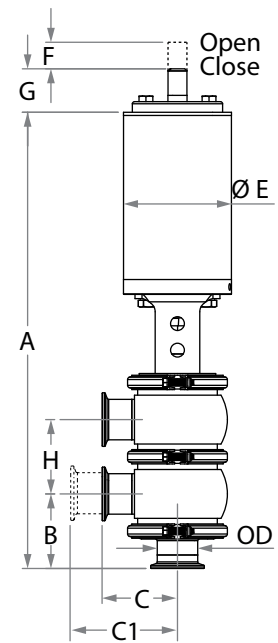

* 1" Valve with long Clamp C1=3.0

Weld Ends (79)

Size/OD		Name	Item	A	B	C	E	G	H	F
1" (25.4)	Epdm	EPVE-79-NC-1.0	611-00690	13.00	2.00	2.00	2.76	1.18	1.97	0.39
	Viton	EPVE-79-NC-1.0-V	611-00831	(330.2)	(50.8)	(50.8)	(70)	(30)	(50)	(10)
	Silicone	EPVE-79-NC-1.0-S	611-00948							
1½" (38.1)	Epdm	EPVE-79-NC-1.5	611-00474	16.38	2.24	2.76	4.00	1.38	2.76	0.96
	Viton	EPVE-79-NC-1.5-V	611-00028	(416)	(57)	(70)	(101.6)	(35)	(70)	(24.5)
	Silicone	EPVE-79-NC-1.5-S	611-00949							
2" (50.8)	Epdm	EPVE-79-NC-2.0	611-00413	17.76	3.00	3.50	4.00	1.38	3.11	0.96
	Viton	EPVE-79-NC-2.0-V	611-00032	(451)	(76.2)	(89)	(101.6)	(35)	(79)	(24.4)
	Silicone	EPVE-79-NC-2.0-S	611-00950							
2½" (63.5)	Epdm	EPVE-79-NC-2.5	611-00513	20.28	3.00	3.50	5.08	1.69	3.94	1.33
	Viton	EPVE-79-NC-2.5-V	611-00049	(515)	(76.2)	(89)	(129)	(43)	(100)	(33.9)
	Silicone	EPVE-79-NC-2.5-S	611-00951							
3" (76.2)	Epdm	EPVE-79-NC-3.0	611-00515	21.85	3.27	3.74	5.08	1.54	4.76	1.36
	Viton	EPVE-79-NC-3.0-V	611-00835	(555)	(83)	(95)	(129)	(39)	(121)	(34.5)
	Silicone	EPVE-79-NC-3.0-S	611-00952							
4" (101.6)	Epdm	EPVE-79-NC-4.0	611-00878	27.32	5.00	4.92	6.61	1.65	5.91	1.18
	Viton	EPVE-79-NC-4.0-V	611-00889	(694)	(127)	(125)	(168)	(42)	(150)	(30)
	Silicone	EPVE-79-NC-4.0-S	611-00953							

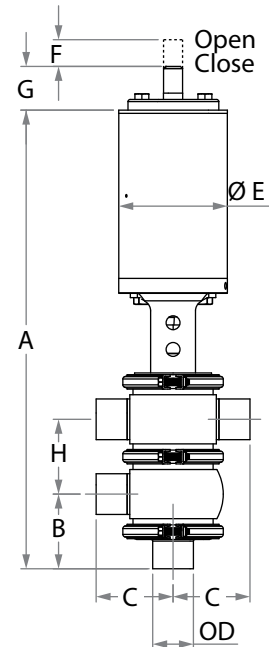

Clamp Ends (79)

Size/OD		Name	Item	A	B	C	E	G	H	F
1"* (25.4)	Epdm	EGPVE-79-NC-1.0	611-00759	12.91	2.00	2.00	2.76	1.26	1.89	0.39
	Viton	EGPVE-79-NC-1.0-V	611-00794	(328)	(50.8)	(50.8)	(70)	(32)	(48)	(10)
	Silicone	EGPVE-79-NC-1.0-S	611-00908							
1½" (38.1)	Epdm	EGPVE-79-NC-1.5	611-00490	16.89	2.76	2.76	4.00	1.38	2.76	0.96
	Viton	EGPVE-79-NC-1.5-V	611-00796	(429)	(70)	(70)	(101.6)	(35)	(70)	(24.5)
	Silicone	EGPVE-79-NC-1.5-S	611-00909							
2" (50.8)	Epdm	EGPVE-79-NC-2.0	611-00491	18.27	3.50	3.50	4.00	1.38	3.11	0.96
	Viton	EGPVE-79-NC-2.0-V	611-00798	(464)	(89)	(89)	(101.6)	(35)	(79)	(24.4)
	Silicone	EGPVE-79-NC-2.0-S	611-00910							
2½" (63.5)	Epdm	EGPVE-79-NC-2.5	611-00492	20.75	3.50	3.50	5.08	1.69	3.94	1.33
	Viton	EGPVE-79-NC-2.5-V	611-00800	(527)	(89)	(89)	(129)	(43)	(100)	(33.9)
	Silicone	EGPVE-79-NC-2.5-S	611-00911							
3" (76.2)	Epdm	EGPVE-79-NC-3.0	611-00493	22.36	3.74	3.74	5.08	1.54	4.76	1.36
	Viton	EGPVE-79-NC-3.0-V	611-00802	(568)	(95)	(95)	(129)	(39)	(121)	(34.5)
	Silicone	EGPVE-79-NC-3.0-S	611-00912							
4" (101.6)	Epdm	EGPVE-79-NC-4.0	611-00876	27.32	5.00	4.88	6.61	1.65	5.91	1.18
	Viton	EGPVE-79-NC-4.0-V	611-00886	(694)	(127)	(124)	(168)	(42)	(150)	(30)
	Silicone	EGPVE-79-NC-4.0-S	611-00913							

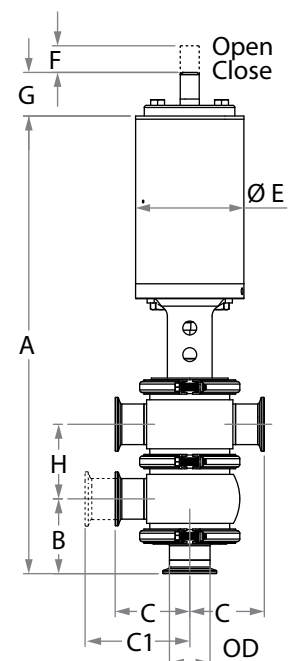

* 1" Valve with long Clamp C1=3.0

3A PVE Divert Valve Dimensions

Weld Ends (97)

Size/OD		Name	Item	A	B	C	E	G	H	F
1" (25.4)	Epdm	EPVE-97-NC-1.0	611-00760	13.00 (330.2)	2.00 (50.8)	2.00 (50.8)	2.76 (70)	1.18 (30)	1.97 (50)	0.39 (10)
	Viton	EPVE-97-NC-1.0-V	611-00839							
	Silicone	EPVE-97-NC-1.0-S	611-00960							
1½" (38.1)	Epdm	EPVE-97-NC-1.5	611-00554	16.38 (416)	2.24 (57)	2.76 (70)	4.00 (101.6)	1.38 (35)	2.76 (70)	0.96 (24.5)
	Viton	EPVE-97-NC-1.5-V	611-00841							
	Silicone	EPVE-97-NC-1.5-S	611-00961							
2" (50.8)	Epdm	EPVE-97-NC-2.0	611-00555	17.76 (451)	3.00 (76.2)	3.50 (89)	4.00 (101.6)	1.38 (35)	3.11 (79)	0.96 (24.4)
	Viton	EPVE-97-NC-2.0-V	611-00423							
	Silicone	EPVE-97-NC-2.0-S	611-00962							
2½" (63.5)	Epdm	EPVE-97-NC-2.5	611-00568	20.28 (515)	3.00 (76.2)	3.50 (89)	5.08 (129)	1.69 (43)	3.94 (100)	1.33 (33.9)
	Viton	EPVE-97-NC-2.5-V	611-00842							
	Silicone	EPVE-97-NC-2.5-S	611-00963							
3" (76.2)	Epdm	EPVE-97-NC-3.0	611-00570	21.85 (555)	3.27 (83)	3.74 (95)	5.08 (129)	1.54 (39)	4.76 (121)	1.36 (34.5)
	Viton	EPVE-97-NC-3.0-V	611-00843							
	Silicone	EPVE-97-NC-3.0-S	611-00964							
4" (101.6)	Epdm	EPVE-97-NC-4.0	611-00882	27.32 (694)	5.00 (127)	4.92 (125)	6.61 (168)	1.65 (42)	5.91 (150)	1.18 (30)
	Viton	EPVE-97-NC-4.0-V	611-00892							
	Silicone	EPVE-97-NC-4.0-S	611-00965							

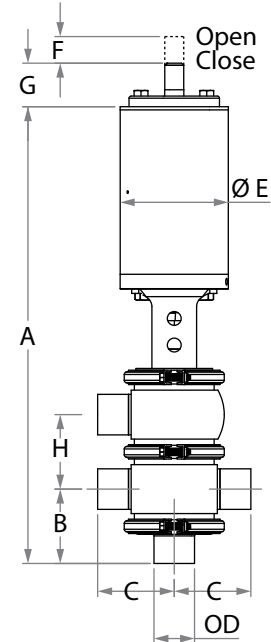

Clamp Ends (97)

Size/OD		Name	Item	A	B	C	E	G	H	F
1"* (25.4)	Epdm	EGPVE-97-NC-1.0	611-00805	12.91 (328)	2.00 (50.8)	2.00 (50.8)	2.76 (70)	1.26 (32)	1.89 (48)	0.39 (10)
	Viton	EGPVE-97-NC-1.0-V	611-00806							
	Silicone	EGPVE-97-NC-1.0-S	611-00920							
1½" (38.1)	Epdm	EGPVE-97-NC-1.5	611-00807	16.89 (429)	2.76 (70)	2.76 (70)	4.00 (101.6)	1.38 (35)	2.76 (70)	0.96 (24.5)
	Viton	EGPVE-97-NC-1.5-V	611-00808							
	Silicone	EGPVE-97-NC-1.5-S	611-00921							
2" (50.8)	Epdm	EGPVE-97-NC-2.0	611-00774	18.27 (464)	3.50 (89)	3.50 (89)	4.00 (101.6)	1.38 (35)	3.11 (79)	0.96 (24.4)
	Viton	EGPVE-97-NC-2.0-V	611-00809							
	Silicone	EGPVE-97-NC-2.0-S	611-00922							
2½" (63.5)	Epdm	EGPVE-97-NC-2.5	611-01000	20.75 (527)	3.50 (89)	3.50 (89)	5.08 (129)	1.69 (43)	3.94 (100)	1.33 (33.9)
	Viton	EGPVE-97-NC-2.5-V	611-00810							
	Silicone	EGPVE-97-NC-2.5-S	611-00923							
3" (76.2)	Epdm	EGPVE-97-NC-3.0	611-00811	22.36 (568)	3.74 (95)	3.74 (95)	5.08 (129)	1.54 (39)	4.76 (121)	1.36 (34.5)
	Viton	EGPVE-97-NC-3.0-V	611-00812							
	Silicone	EGPVE-97-NC-3.0-S	611-00924							
4" (101.6)	Epdm	EGPVE-97-NC-4.0	611-00880	27.32 (694)	5.00 (127)	4.88 (124)	6.61 (168)	1.65 (42)	5.91 (150)	1.18 (30)
	Viton	EGPVE-97-NC-4.0-V	611-00890							
	Silicone	EGPVE-97-NC-4.0-S	611-00925							

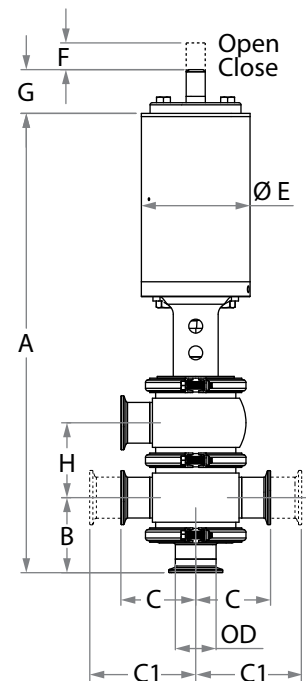

* 1" Valve with long Clamp C1=3.0

Weld Ends (99)

Size/OD		Name	Item	A	B	C	E	G	H	F
1" (25.4)	Epdm	EPVE-99-NC-1.0	611-00692	13.00	2.00	2.00	2.76	1.18	1.97	0.39
	Viton	EPVE-99-NC-1.0-V	611-00844	(330.2)	(50.8)	(50.8)	(70)	(30)	(50)	(10)
	Silicone	EPVE-99-NC-1.0-S	611-00966							
1½" (38.1)	Epdm	EPVE-99-NC-1.5	611-00524	16.38	2.76	2.76	4.00	1.38	2.76	0.96
	Viton	EPVE-99-NC-1.5-V	611-00845	(416)	(70)	(70)	(101.6)	(35)	(70)	(24.5)
	Silicone	EPVE-99-NC-1.5-S	611-00967							
2" (50.8)	Epdm	EPVE-99-NC-2.0	611-00525	17.76	3.00	3.50	4.00	1.38	3.11	0.96
	Viton	EPVE-99-NC-2.0-V	611-00846	(451)	(76.2)	(89)	(101.6)	(35)	(79)	(24.4)
	Silicone	EPVE-99-NC-2.0-S	611-00968							
2½" (63.5)	Epdm	EPVE-99-NC-2.5	611-00567	20.28	3.00	3.50	5.08	1.69	3.94	1.33
	Viton	EPVE-99-NC-2.5-V	611-00847	(515)	(76.2)	(89)	(129)	(43)	(100)	(33.9)
	Silicone	EPVE-99-NC-2.5-S	611-00969							
3" (76.2)	Epdm	EPVE-99-NC-3.0	611-00569	21.85	3.23	3.74	5.08	1.54	4.76	1.36
	Viton	EPVE-99-NC-3.0-V	611-00867	(555)	(82)	(95)	(129)	(39)	(121)	(34.5)
	Silicone	EPVE-99-NC-3.0-S	611-00970							
4" (101.6)	Epdm	EPVE-99-NC-4.0	611-00883	27.32	5.00	4.92	6.61	1.65	5.91	1.18
	Viton	EPVE-99-NC-4.0-V	611-00893	(694)	(127)	(125)	(168)	(42)	(150)	(30)
	Silicone	EPVE-99-NC-4.0-S	611-00971							

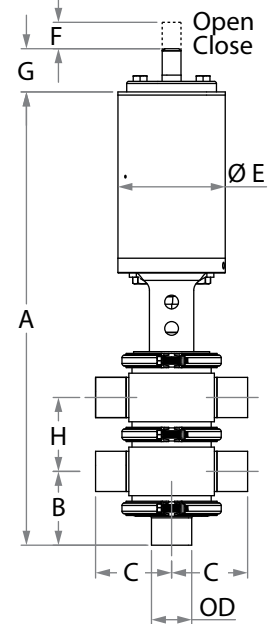

Clamp Ends (99)

Size/OD		Name	Item	A	B	C	E	G	H	F
1"* (25.4)	Epdm	EGPVE-99-NC-1.0	611-00528	12.91	2.00	2.00	2.76	1.26	1.89	0.39
	Viton	EGPVE-99-NC-1.0-V	611-00814	(328)	(50.8)	(50.8)	(70)	(32)	(48)	(10)
	Silicone	EGPVE-99-NC-1.0-S	611-00926							
1½" (38.1)	Epdm	EGPVE-99-NC-1.5	611-00529	16.89	2.76	2.76	4.00	1.38	2.76	0.96
	Viton	EGPVE-99-NC-1.5-V	611-00815	(429)	(70)	(70)	(101.6)	(35)	(70)	(24.5)
	Silicone	EGPVE-99-NC-1.5-S	611-00927							
2" (50.8)	Epdm	EGPVE-99-NC-2.0	611-00530	18.27	3.50	3.50	4.00	1.38	3.11	0.96
	Viton	EGPVE-99-NC-2.0-V	611-00816	(464)	(89)	(89)	(101.6)	(35)	(79)	(24.4)
	Silicone	EGPVE-99-NC-2.0-S	611-00928							
2½" (63.5)	Epdm	EGPVE-99-NC-2.5	611-00531	20.75	3.50	3.50	5.08	1.69	3.94	1.33
	Viton	EGPVE-99-NC-2.5-V	611-00817	(527)	(89)	(89)	(129)	(43)	(100)	(33.9)
	Silicone	EGPVE-99-NC-2.5-S	611-00929							
3" (76.2)	Epdm	EGPVE-99-NC-3.0	611-00818	22.36	3.74	3.74	5.08	1.54	4.76	1.36
	Viton	EGPVE-99-NC-3.0-V	611-00840	(568)	(95)	(95)	(129)	(39)	(121)	(34.5)
	Silicone	EGPVE-99-NC-3.0-S	611-00930							
4" (101.6)	Epdm	EGPVE-99-NC-4.0	611-00881	27.32	5.00	4.88	6.61	1.65	5.91	1.18
	Viton	EGPVE-99-NC-4.0-V	611-00891	(694)	(127)	(124)	(168)	(42)	(150)	(30)
	Silicone	EGPVE-99-NC-4.0-S	611-00931							

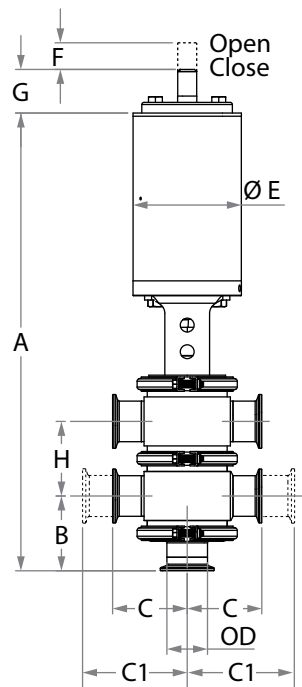

* 1" Valve with long Clamp C1=3.0

3A PVE Divert Valve Components & Materials

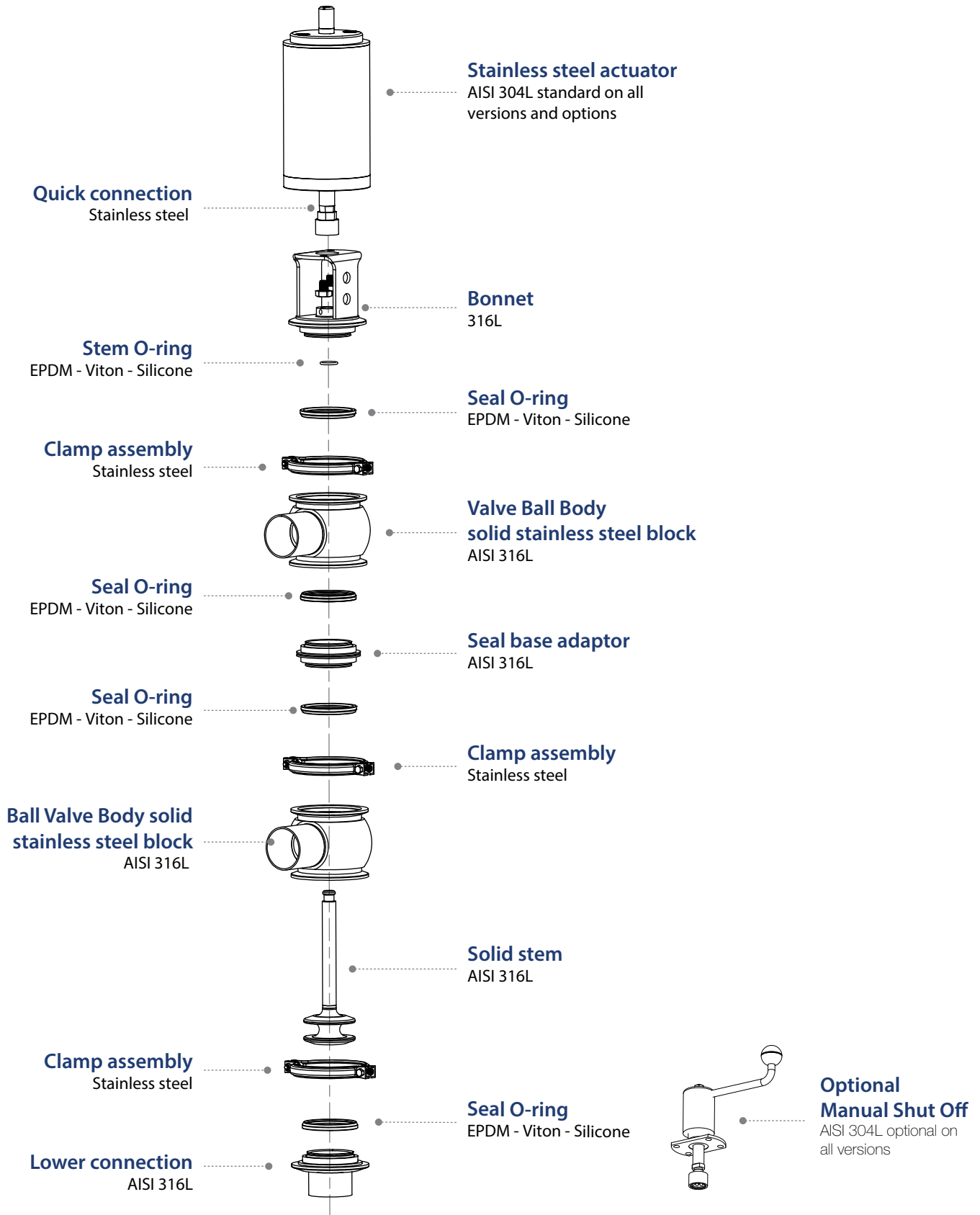

3A PVE Divert Valve Pressure Drop Vs Flow Rate Capacity Diagram

$$HI = \frac{K \cdot F^2}{2g \cdot D^4}$$

HI - Head Loss [ft]
 K - Loss coefficient []
 F - Flow Rate capacity [ft³/h]
 g - Gravitational acceleration [ft/s²]
 D - Valve diameter [inch]

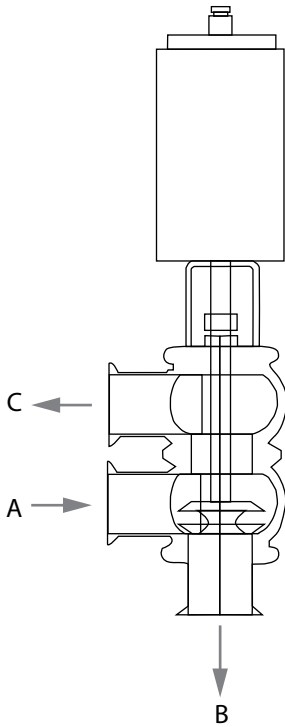

Pressure drop - Divert Valve* (A-B) K=2E5

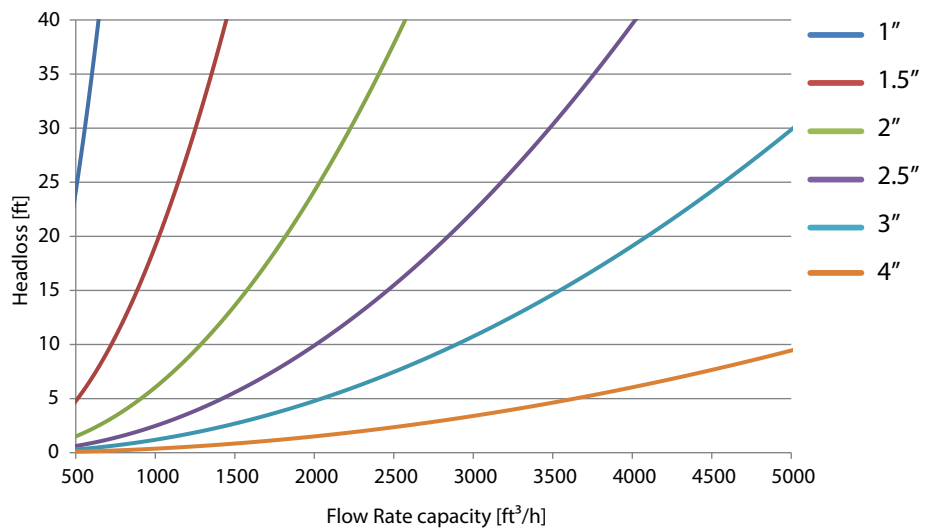

Pressure drop - Divert Valve* (A-C) K=4E5

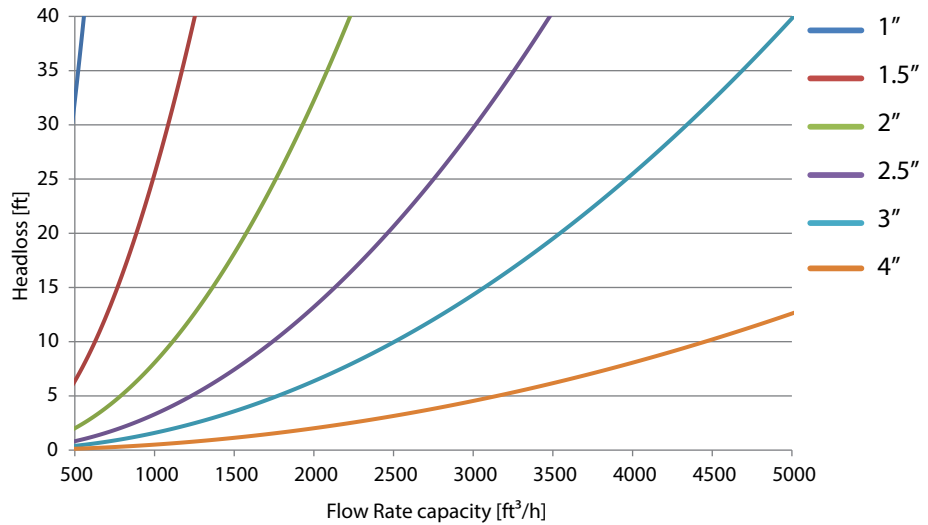

* For additional valve configuration (79, 97, 99) please refer to EGMO website

3A PVE - Pressure Relief Valve (Overflow Valve)

The primary purpose of a pressure- or vacuum-relief valve is to protect life and property by venting process fluid from an over-pressurized vessel, or adding fluid or gas (such as air) to prevent the formation of a vacuum strong enough to collapse a storage tank.

- ✓ Operates as a pressure-release valve with the option to completely open the valve using a pneumatic actuator
- ✓ Overflow valves are used mainly for automatic CIP operation or bypass

Pressure Relief Valve Properties:

- ✓ Operating pressure 2- 7 bar
- ✓ Pressure to open pneumatically - Min 5 - Max 8 bar
- ✓ Construction materials:
 - Actuator: AISI 304L
 - Valve Body: AISI 316L & EPDM / Silicone / Viton gaskets
- ✓ Process contact components are electric-polished
- ✓ Inside surface finish $\leq 32 \mu\text{in Ra}$



How To Order Pressure Relief Valve

E G P V E - RELIEF - 1 . 0 - V

Valve Type Valve Configuration Size Seals

Type Connection	Valve Configuration	Size	Seals	Control
EGPVE - CLAMP EPVE - WELD	Relief	1.0* 1.5 2.0 2.5* 3.0*	DEFAULT - EPDM V - Viton S - Silicone	1IPS - One Inductive Proximity Switch 2IPS - Two Inductive Proximity Switch (Proximity Switch Diameter 12mm)

* Available upon request

3A PVE Tank Bottom Valve

The Tank Bottom valve is a pneumatically actuated single seat valve used to shut off fluid media at vessels or tanks. Tank Bottom valves are assembled at the bottom of tanks in the dairy, food & beverage, pharmaceutical and chemical industries.

Constructed from AISI 316L Stainless steel and electro-polished, the Tank Bottom valve optimizes CIP/SIP procedures by ensuring complete drainage of the tank.

Key Advantages:

- ✓ Easy and quick assembly / disassembly due to one piece valve structure
- ✓ Zero dead leg design with minimum maintenance requirements
- ✓ Designed to fully drain the tank

Tank Bottom Valve Properties:

- ✓ Operating pressure 2-7 bar
- ✓ Pressure to open pneumatically - Min 5 - Max 8 bar
- ✓ Construction materials:
 - Actuator: AISI 304L
 - Valve Body: AISI 316L & EPDM / Silicone / Viton gaskets
- ✓ Process contact components are electric-polished
- ✓ Inside surface finish $\leq 32 \mu\text{m Ra}$



How To Order Tank Bottom Valve

E G P V E - TANK - N C - 1 . 0 - V - A S I

Valve Type Valve Configuration Actuation Type Size Seals Control Head

Type Connection	Valve Configuration	Actuation Type	Size	Seals	Control Head
EGPVE - CLAMP	Tank	NC	1.0	DEFAULT - EPDM	ASI
EPVE - WELD		NO	1.5	V - Viton	24V
			2.0	S - Silicone	110V
			2.5		1IPS - One Inductive Proximity Switch
			3.0		2IPS - Two Inductive Proximity Switch (Proximity Switch Diameter 12mm)

3A PVE Pressure Relief Valve Dimensions

Weld Ends (7)

Size/OD		Name	Item	A	B	C	E
1½" (38.1)	Epdm	EPVE-RELIEF-1.5	611-00980	17.40 (442)	2.24 (57)	2.76 (70)	4.00 (101.6)
	Viton	EPVE-RELIEF-1.5-V	611-00988				
	Silicone	EPVE-RELIEF-1.5-S	611-00996				
2" (50.8)	Epdm	EPVE-RELIEF-2.0	611-00981	18.31 (465)	3.00 (76.2)	3.50 (89)	4.00 (101.6)
	Viton	EPVE-RELIEF-2.0-V	611-00989				
	Silicone	EPVE-RELIEF-2.0-S	611-00997				
2½"* (63.5)	Epdm	EPVE-RELIEF-2.5	611-00982	N/A	N/A	N/A	N/A
	Viton	EPVE-RELIEF-2.5-V	611-00990				
	Silicone	EPVE-RELIEF-2.5-S	611-00998				
3"* (76.2)	Epdm	EPVE-RELIEF-3.0	611-00983	N/A	N/A	N/A	N/A
	Viton	EPVE-RELIEF-3.0-V	611-00991				
	Silicone	EPVE-RELIEF-3.0-S	611-00999				

* Available upon request

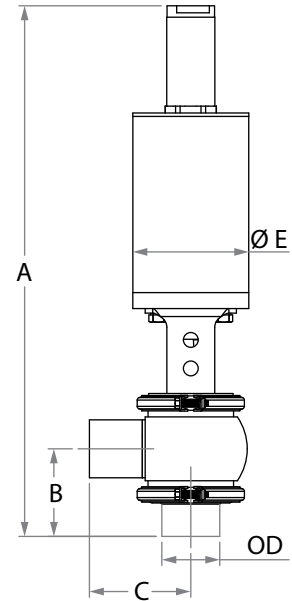

Clamp Ends (7)

Size/OD		Name	Item	A	B	C	E
1½" (38.1)	Epdm	EGPVE-RELIEF-1.5	611-00976	17.87 (454)	2.76 (70)	2.76 (70)	4.00 (101.6)
	Viton	EGPVE-RELIEF-1.5-V	611-00984				
	Silicone	EGPVE-RELIEF-1.5-S	611-00992				
2" (50.8)	Epdm	EGPVE-RELIEF-2.0	611-00977	18.82 (478)	3.50 (89)	3.50 (89)	4.00 (101.6)
	Viton	EGPVE-RELIEF-2.0-V	611-00985				
	Silicone	EGPVE-RELIEF-2.0-S	611-00993				
2½"* (63.5)	Epdm	EGPVE-RELIEF-2.5	611-00978	N/A	N/A	N/A	N/A
	Viton	EGPVE-RELIEF-2.5-V	611-00986				
	Silicone	EGPVE-RELIEF-2.5-S	611-00994				
3"* (76.2)	Epdm	EGPVE-RELIEF-3.0	611-00979	N/A	N/A	N/A	N/A
	Viton	EGPVE-RELIEF-3.0-V	611-00987				
	Silicone	EGPVE-RELIEF-3.0-S	611-00995				

* Available upon request

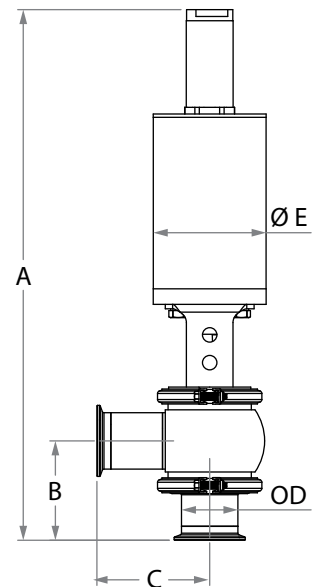

3A PVE Tank Bottom Valve Dimensions

Weld Ends (7)

Size/OD		Name	Item	A	B	C	E	G	F
1" (25.4)	Epdm	EPVE-TANK-1.0	611-01002						
	Viton	EPVE-TANK-1.0-V	611-01004	N/A	N/A	N/A	N/A	N/A	N/A
	Silicone	EPVE-TANK-1.0-S	611-01006						
1½" (38.1)	Epdm	EPVE-TANK-1.5	611-00015						
	Viton	EPVE-TANK-1.5-V	611-00853	13.82 (351)	2.36 (60)	5.91 (150)	4.00 (101.6)	2.32 (59)	1.00 (25.4)
	Silicone	EPVE-TANK-1.5-S	611-00972						
2" (50.8)	Epdm	EPVE-TANK-2.0	611-00318						
	Viton	EPVE-TANK-2.0-V	611-00855	14.21 (361)	2.56 (65)	5.91 (150)	4.00 (101.6)	2.36 (60)	1.06 (26.8)
	Silicone	EPVE-TANK-2.0-S	611-00973						
2½" (63.5)	Epdm	EPVE-TANK-2.5	611-00559						
	Viton	EPVE-TANK-2.5-V	611-00857	15.35 (390)	3.23 (82)	7.09 (180)	4.00 (101.6)	2.17 (55)	1.00 (25.4)
	Silicone	EPVE-TANK-2.5-S	611-00974						
3" (76.2)	Epdm	EPVE-TANK-3.0	611-00605						
	Viton	EPVE-TANK-3.0-V	611-00859	17.76 (451)	3.82 (97)	7.87 (200)	5.08 (129)	2.05 (52)	1.53 (38.9)
	Silicone	EPVE-TANK-3.0-S	611-00975						

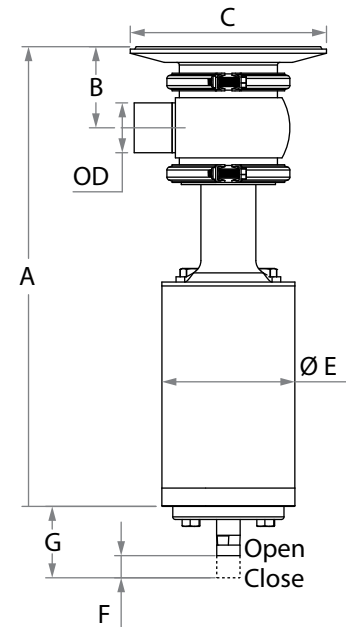

Clamp Ends (7)

Size/OD		Name	Item	A	B	C	E	G	F
1" (25.4)	Epdm	EGPVE-TANK-1.0	611-01001						
	Viton	EGPVE-TANK-1.0-V	611-01003	N/A	N/A	N/A	N/A	N/A	N/A
	Silicone	EGPVE-TANK-1.0-S	611-01005						
1½" (38.1)	Epdm	EGPVE-TANK-1.5	611-00822						
	Viton	EGPVE-TANK-1.5-V	611-00823	13.82 (351)	2.36 (60)	5.91 (150)	4.00 (101.6)	2.32 (59)	1.00 (25.4)
	Silicone	EGPVE-TANK-1.5-S	611-00932						
2" (50.8)	Epdm	EGPVE-TANK-2.0	611-00824						
	Viton	EGPVE-TANK-2.0-V	611-00825	14.21 (361)	2.56 (65)	5.91 (150)	4.00 (101.6)	2.36 (60)	1.06 (26.8)
	Silicone	EGPVE-TANK-2.0-S	611-00933						
2½" (63.5)	Epdm	EGPVE-TANK-2.5	611-00826						
	Viton	EGPVE-TANK-2.5-V	611-00896	15.35 (390)	3.23 (82)	7.09 (180)	4.00 (101.6)	2.17 (55)	1.00 (25.4)
	Silicone	EGPVE-TANK-2.5-S	611-00934						
3" (76.2)	Epdm	EGPVE-TANK-3.0	611-00827						
	Viton	EGPVE-TANK-3.0-V	611-00828	17.76 (451)	3.82 (97)	7.87 (200)	5.08 (129)	2.05 (52)	1.53 (38.9)
	Silicone	EGPVE-TANK-3.0-S	611-00935						

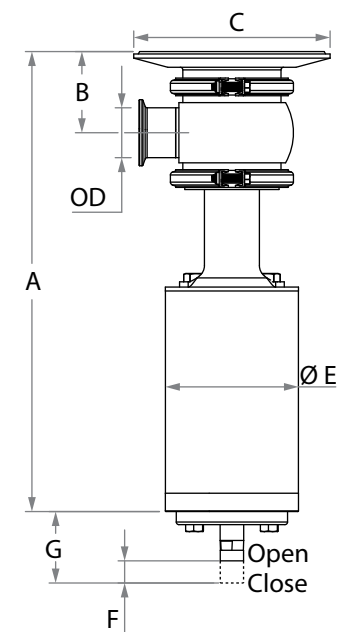

3A PVE Pressure Relief Valve Components & Materials

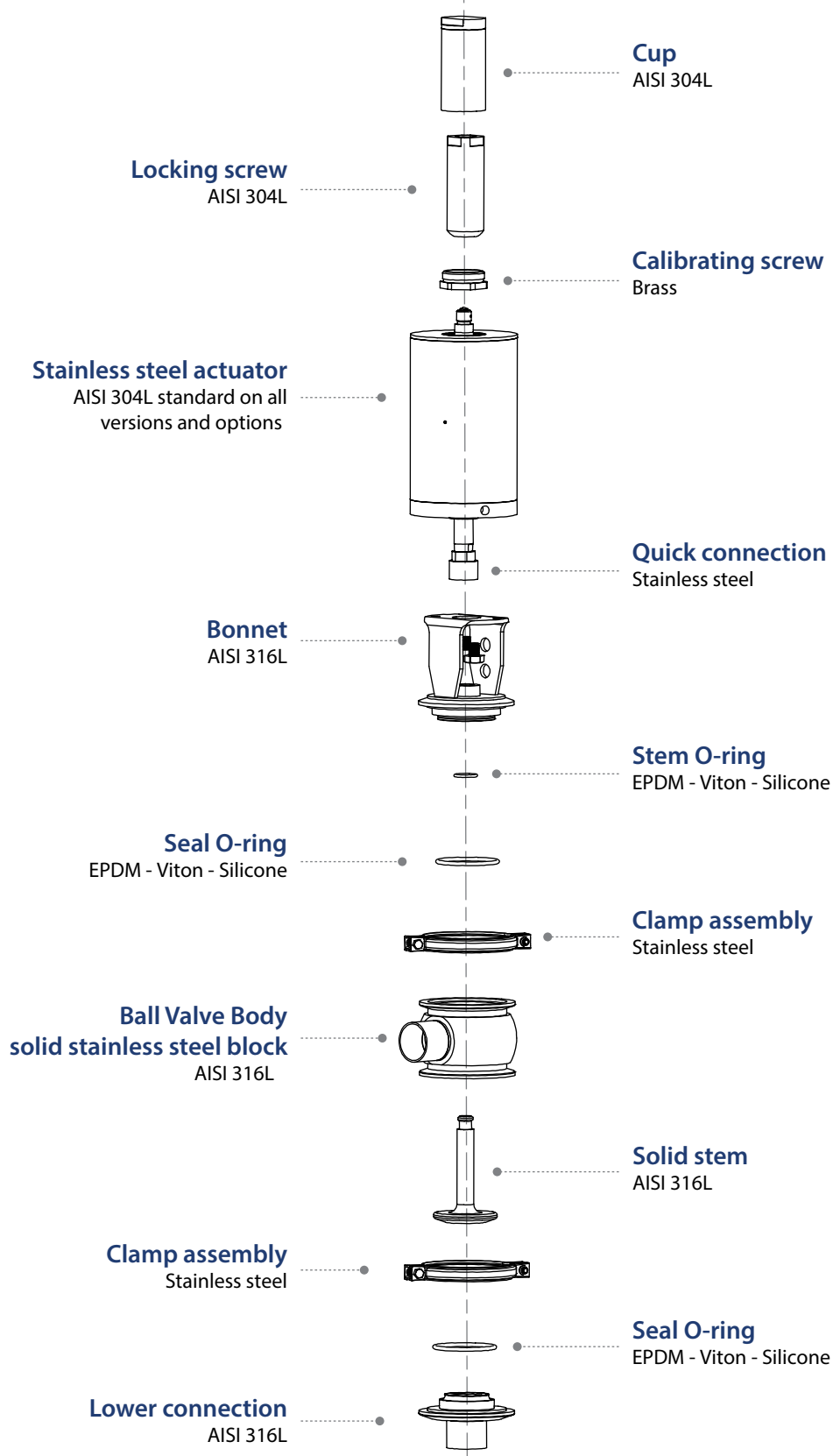

3A PVE Tank Bottom Valve Components & Materials

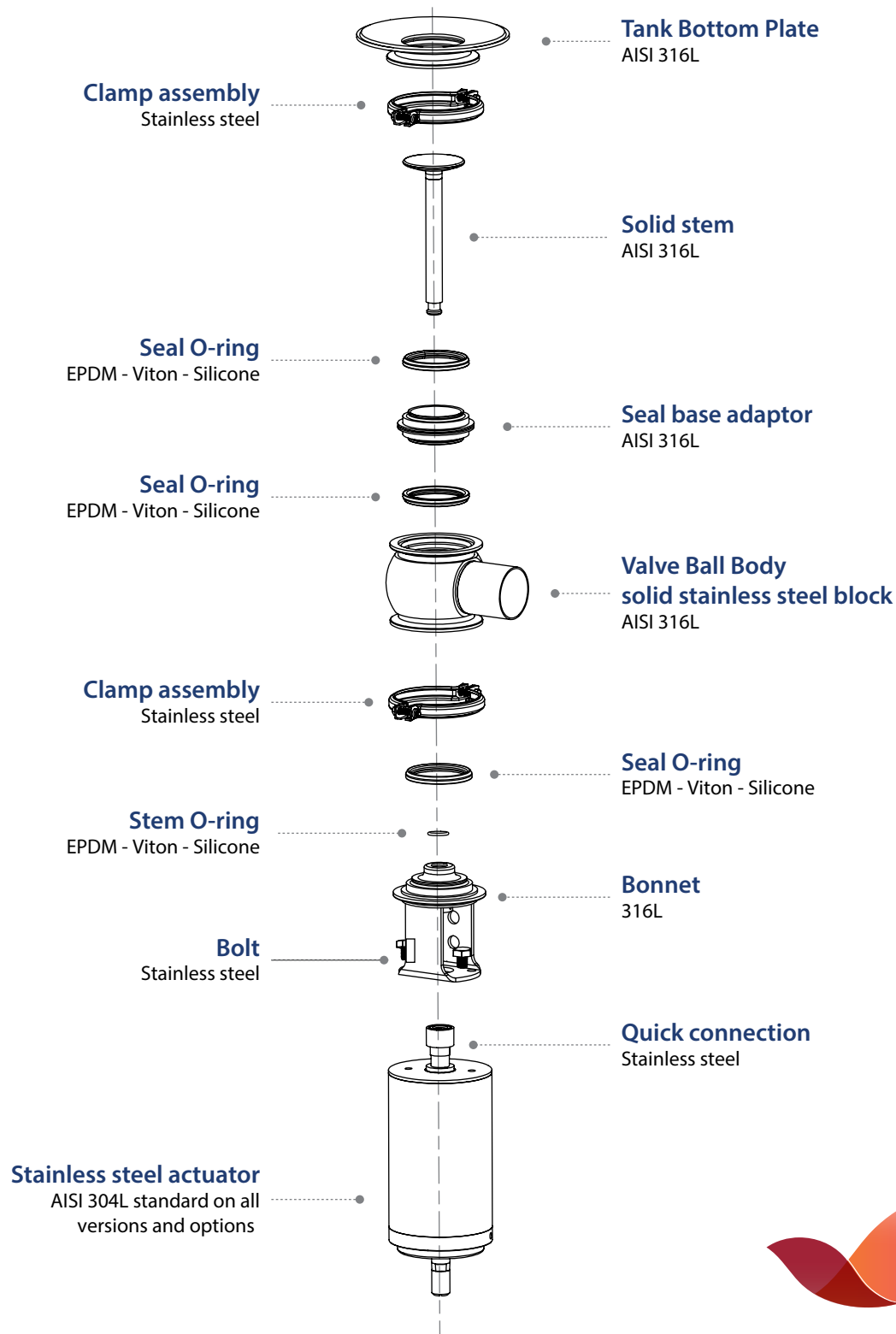

3A PVE Control Head

The 3A PVE Control Head is used to activate and indicate the valve position, giving both electrical and visual signals

- ✓ Linear control head is compatible with most PLC automated systems
- ✓ Digital communication or ASI BUS (AS-interface)
- ✓ Reliable & Cost-Effective
- ✓ Easy maintenance
- ✓ Compact

Technical specifications

Body Material:	POM
Cover:	Polycarbonate
Sealing:	NBR
Protection class:	IP67
Supply Voltage:	24 [VDC], 110 [VAC], ASIBUS (30 [VDC])
Max. Working temperature	-10°C (14°F) to 50°C (122°F)
Solenoid Valve type:	3/2way (Air/Spring)
Electrical multiple connections:	M12X1 (4&5-pole) connector
Feedback:	Pos. Open (digital) Pos. Closed (digital)
Power consumption:	2.0 [W]
Weight:	400 [gr], lbs 0.88
Dimensions:	diameter 70 [mm] 2.75", height: 120 [mm] 4.72"

Control Head - Versions

Name	Part Number	Pneumatic Operation	Power Supply			Notes
		Spring/Air 3/2	24VDC	110VDC	ASIBUS	
PVEP-CH-SR-24VDC	618-00932	✓	✓			
PVEP-CH-SR-ASIBUS	618-00931	✓			✓	29.5 ~ 31.5 VDC
PVEP-CH-SR-110VDC	618-00930	✓		✓		

How To Order

To specify the part completely, start with the product description and select the additional options as shown below:

PVEP	-	CH	-	SR	-	24V
		Product Line			Power Supply	
		Control head PVE - Linear			24V - 24VDC 110V - 110AC ASI BUS	
			Action			
			SR - Spring Return			



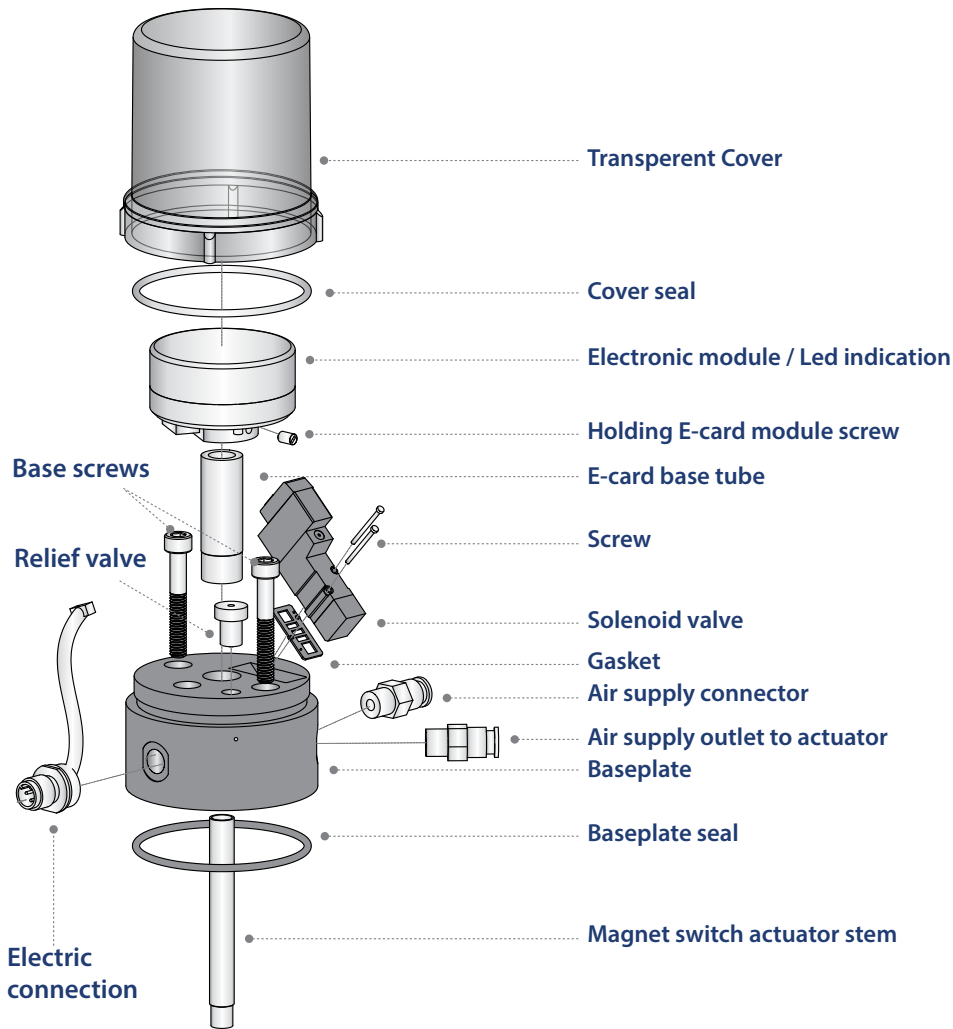

PVE Control Head Dimensions

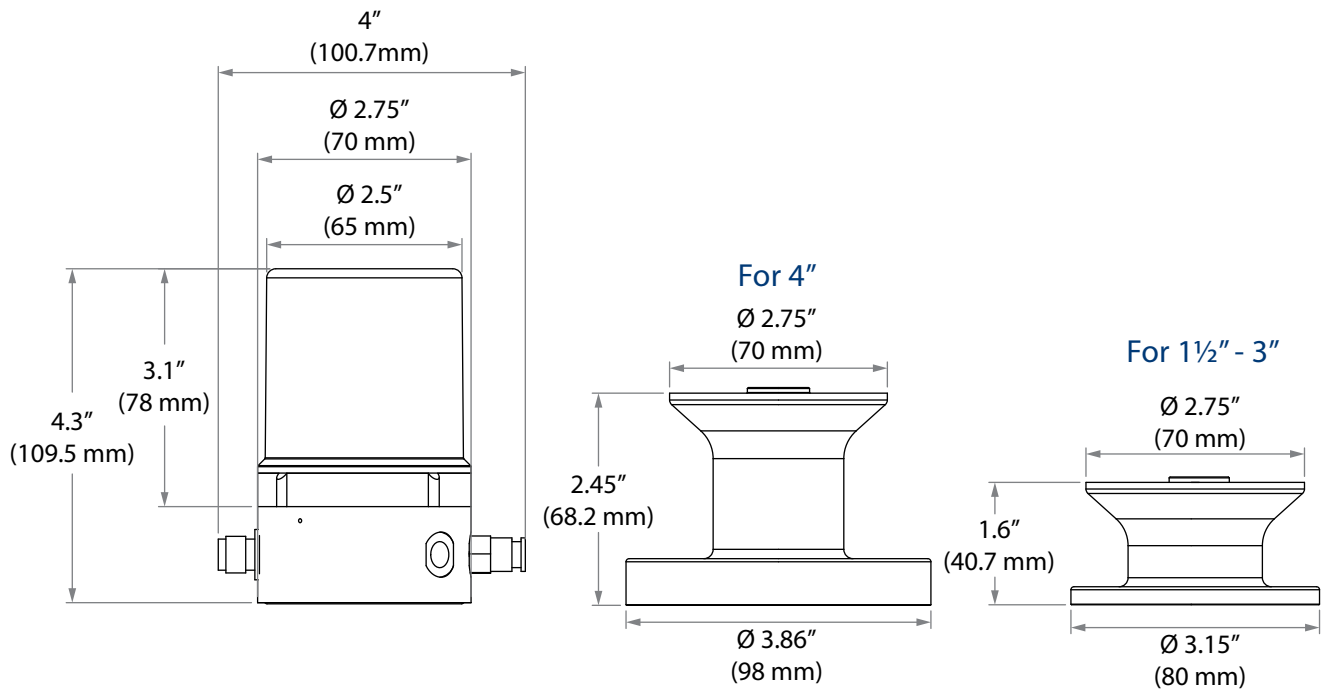

Note: For additional information on mounting kits refer to the user manual

Control Head Types

24VDC

- ✓ Direct I/O 24VDC Valve controller
 - ✓ With integrated LED dome
(Green-closed / Amber-open)
 - ✓ With Auto calibration for position indication
 - ✓ Mounting on Valve through mounting kit
- Direct I/O controller for linear Valves spring return

Equipped with:

- Baseplate (POM)
- 3/2 way Solenoid
- Transparent screw cover
- With auto calibration for position indication
- With LED DOME
- 5-pole M12x1 connector
- Air connection for 6 mm air hose

110VDC

- ✓ Direct I/O 110VAC Valve controller
 - ✓ With integrated LED dome
(Green-closed / Amber-open)
 - ✓ With Auto calibration for position indication
 - ✓ Mounting on Valve through mounting kit
- Direct I/O controller for linear Valves spring return

Equipped with:

- Baseplate (POM)
- 3/2 way Solenoid
- Transparent screw cover
- With auto calibration for position indication
- With LED DOME
- 5-pole M12x1 connector
- Air connection for 6 mm air hose

ASI

- ✓ AS-Interface Valve controller
 - ✓ With integrated LED dome
(Green-closed / Amber-open)
 - ✓ With Auto calibration for position indication
 - ✓ Mounting on Valve through mounting kit
 - ✓ Slave Profile : S-3/A.0.E
- AS-Interface controller for linear Valves spring return

Equipped with:

- Baseplate (POM)
- 3/2 way Solenoid
- Transparent screw cover
- with auto calibration for position indication
- 1 AS-Interface electronic module with LED DOME
- 4-pole M12x1 connector
- Air connection for 6 mm air hose



Technical Data

ASI - ASVC 24 VDC / 110 VAC

Material Body Cover sealing	Pom (black) Polycarbonate, (transparent brown) NBR
Supply Voltage	ASI - 31,6 VDC 24 VDC 110 VAC
Electrical connection Multipole connection	ASI - M12x1 (4-pole) connector 24 VDC / 110 VAC - M12x1 (5-pole) connector
ASI Only - AS-Interface specification	3.0
ASI Only - AS-Interface profile:	S-3/A.0.E 3
ASI Only - I/O code: ID code: Id1 code: Id2 code:	A 0 E
Feedback	Yes
Pos. open (digital) Pos. Closed (digital)	Yes
Power consumption max.	2 Watt
Stroke range Valve spindel	0.2" - 2.75"
Solenoid valve type	3/2-way NC
Power consumption [Vdc/W] Response time [ms]	98
Orifice [l/min]	
Seal-material	NBR
Supply pressure	7 Bar max
Control medium Dust concentration Particle density	Neutral gases, air DIN ISO 8573-1 Class 3 (<5µm particle size) Class 3 (<5mg/m ³)
Pressure condensation point Oil concentration	Class 3 (<-20°C) Class 1 (< 0,01 mg/m ³)
Pilot air ports	1/8"G / plug-on fitting 6.0
Ambient temperature	-10.....+50°C (no freezing.)
Electrical Protection class	III
Housing protection class	IP 67
Installation	As required, preferably with actuator in upright position
Dimensions BxH	2.75" - 3.94"
ASI Only - OPTIONS AS-Interface profile	Client spec.

Maximum Working Pressure Data

Spring Actuator

■ Media ■ Air

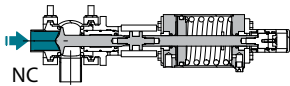
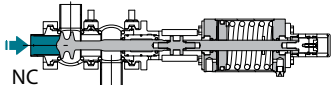
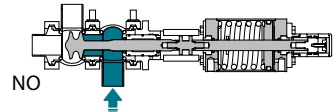
Actuator & Valve body combinations	Actuator Mode	Air pressure	Valve Size					
			1"	1½"	2"	2 ½"	3"	4"
			PVE0	PVE1	PVE1	PVE2	PVE2	PVE3
 NC	Spring	0 Bar	7.0	11.5	6.0	6.5	4.5	5.0
	Spring	0 PSI	102	167	87	94	65	73
 NC	Spring	0 Bar	8.0	11.5	6.0	6.5	4.5	5.0
	Spring	0 PSI	116	167	87	94	65	73
 NO	Spring	0 Bar	9.5	11.5	6.0	6.5	4.5	5.0
	Spring	0 PSI	138	167	87	94	65	73

Air Actuator

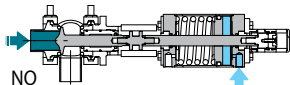
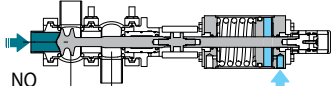
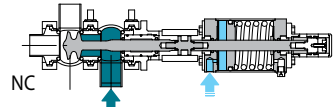
Actuator & Valve body combinations	Actuator Mode	Air pressure	Valve Size					
			1"	1½"	2"	2 ½"	3"	4"
			PVE0	PVE1	PVE1	PVE2	PVE2	PVE3
 NO	Air	5 Bar	6.5	7.5	4.5	5.2	4.5	5.0
	Air	72.5 PSI	94	109	65	75	65	73
 NO	Air	5 Bar	7.0	7.5	4.5	5.2	4.5	5.0
	Air	72.5 PSI	102	109	65	75	65	73
 NC	Air	5 Bar	9.5	7.5	4.5	5.2	4.5	5.0
	Air	72.5 PSI	138	109	65	75	65	73

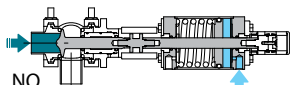
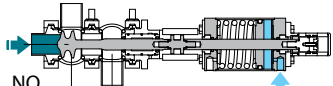
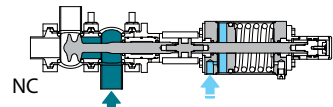
Actuator & Valve body combinations	Actuator Mode	Air pressure	Valve Size					
			1"	1½"	2"	2 ½"	3"	4"
			PVE0	PVE1	PVE1	PVE2	PVE2	PVE3
 NO	Air	6 Bar	9.5	12	7	8.5	6.5	7.0
	Air	87 PSI	138	174	102	123	94	102
 NO	Air	6 Bar	10.0	12.0	7.0	8.5	6.5	7.0
	Air	87 PSI	145	174	102	123	94	102
 NC	Air	6 Bar	12.0	12.0	7.0	8.5	6.5	7.0
	Air	87 PSI	174	174	102	123	94	102

Relief Air Actuator

■ Media ■ Air

Actuator & Valve body combinations	Actuator Mode	Air pressure	Valve Size					
			1"	1½"	2"	2½"	3"	4"
			PVE0	PVE1	PVE1	PVE2	PVE2	PVE3
 NO	Spring	0 Bar	12.5	17.0	9.0	10.0	8.5	6.5
	Spring	0 PSI	181	247	131	145	123	94
 NO	Spring	0 Bar	12.0	17.0	9.0	10.0	8.5	6.5
	Spring	0 PSI	174	247	131	145	123	94
 NC	Spring	0 Bar	9.0	17.0	9.0	10.0	8.5	6.5
	Spring	0 PSI	131	247	131	145	123	94

Compress Air Actuator

Actuator & Valve body combinations	Actuator Mode	Air pressure	Valve Size					
			1"	1½"	2"	2½"	3"	4"
			PVE0	PVE1	PVE1	PVE2	PVE2	PVE3
 NC	Air	5 Bar	12.5	12.5	7.0	7.0	5.0	6.0
	Air	72.5 PSI	181	181	102	102	73	87
 NC	Air	5 Bar	10.5	12.5	7.0	7.0	5.0	6.5
	Air	72.5 PSI	152	181	102	102	73	87
 NO	Air	5 Bar	8.5	12.5	7.0	7.0	5.0	6.5
	Air	72.5 PSI	123	181	102	102	73	87

Actuator & Valve body combinations	Actuator Mode	Air pressure	Valve Size					
			1"	1½"	2"	2½"	3"	4"
			PVE0	PVE1	PVE1	PVE2	PVE2	PVE3
 NC	Air	6 Bar	17.0	18	10	10.0	7.0	8.5
	Air	87 PSI	247	254	145	145	102	123
 NC	Air	6 Bar	15.5	17.5	10.0	10.0	7.0	8.5
	Air	87 PSI	225	254	145	145	102	123
 NO	Air	6 Bar	17.5	17.5	10.0	10.0	7.0	8.5
	Air	87 PSI	254	145	94	102	102	123

NEUMO EHRENBERG GROUP

GLOBAL LOCATIONS



NEUMO GmbH+Co. KG (D)
 Tel: +49 (0) 7043 36 0
 Fax: +49 (0) 7043 36 179
 E-Mail: info@neumo.de
www.neumo.de

GERMANY



VNE Corporation
 Tel: +1 800 356 1111
 +1 608 756 4930
 Fax: +1 608 756 3643
 E-Mail: stainless@vneecorp.com
www.vnestainless.com

U.S.A



EGMO Ltd.
 Tel: +972 (0) 4 9855 176
 +972 (0) 4 9855 111
 Fax: +972 (0) 4 9855 175
 E-Mail: salese@egmo.co.il
www.egmo.co.il

ISRAEL



NEUMO-EGMO Spain S.L
 Tel: +34 977 524 914
 Fax: +34 977 524 898
 E-Mail: neumo-es@neumo-es.com
www.neumo-es.com

SPAIN



HPT Inc.
 Tel: +845.452.1103
 +800.284.4478
 E-Mail: sales@hptinc.com
<http://www.hptinc.com/>

U.S.A



Herli AG
 Tel: +41 (0) 31 750 12 11
 Fax: +41 (0) 31 750 12 00
 E-Mail: info@herli.net
www.herli.net

SWITZERLAND



NEUMO Polska Sp. z.o.o
 Tel: +48 (0) 46 833 4306
 Fax: +48 (0) 46 832 5626
 E-Mail: neumo@neumo.pl

POLAND



NEUMO Turkey
 Tel: +90 (212) 875 01 41
 Fax: +90 (212) 875 23 13
 E-Mail: info@neumo.com.tr
www.neumo.com.tr

TURKEY



NEUMO Budapest Kft
 Tel: +36 (1) 3174177
 +36 (1) 3185982
 Fax: +36 (1) 266 8765
 E-Mail: neumo@neumo.hu
www.neumo.hu

HUNGARY



NEUMO GmbH + Co. KG
 Tel: +84 (4) 3773 6586
 Fax: +84 (4) 3773 6587
 E-Mail: info@neumo.com.vn
www.neumo.co.vn

VIETNAM



NEUMO - VARGUS (Shanghai)
 Trading Co., Ltd
 Tel: +86 (21) 51688300
 Fax: +86 (21) 51688380
 E - Mail: info@neumo.com.cn

CHINA



NEUMO UK Ltd.
 Tel: +44 (0) 1952 583 999
 Fax: +44 (0) 1952 583 958
 E-Mail: stainless@neumo.co.uk
www.neumo.co.uk

UNITED KINGDOM



AWH Armaturenwerke (D)
 Hötensleben GmbH
 Tel: +49 (0) 39405 92 0
 Fax: +49 (0) 39405 92 111
 E-Mail: info@awh.de
www.awh.de

Damstahl GmbH (D)
 Tel: +49 (0) 2173 797 0
 Fax: +49 (0) 2173 797 274
 E-Mail: ds@damstahl.de
www.damstahl.de

Gebr. Rieger GmbH+Co. KG (D)
 Tel: +49 (0) 7361 5702 0
 Fax: +49 (0) 7361 5702 51
 E-Mail: info@rr-rieger.de
www.rr-rieger.de

GERMANY



NEUMO
 Tel: +353 (0)21 4975540
 Cel: +353 (0)87 2330469
 E-Mail: dosullivan@neumo.de
www.neumo.de/en/

IRELAND



Damstahl a/s (Denmark)
 Tel: +45 (0) 8794 4000
 Fax: +45 (0) 8794 4150
 E-Mail: ds@damstahl.com
www.damstahl.dk

DENMARK



Damstahl a/s Oslo (N)
 Tel: +47 5615 1570
 Fax: +47 5615 1571
 E-Mail: dano@damstahl.com
www.damstahl.no

NORWAY



Damstahl a/b (Sweden)
 Tel: +46 87 61 71 00
 Fax: +46 87 61 14 05
www.damstahl.se

SWEDEN



VNE
 valves products
 Scan for detail
 product info



Semiconductor



Bio-Pharm



Hygienic